

A

1

P

2

F

3

W

4

16

5

1 Shape

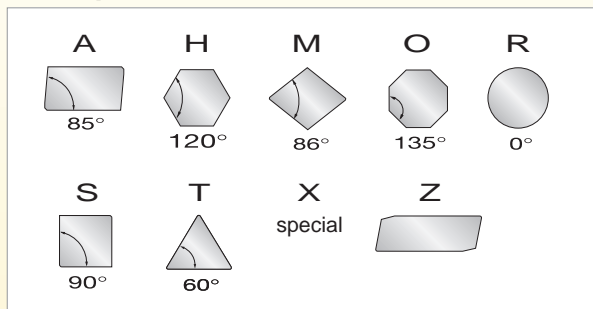

2 Clearance

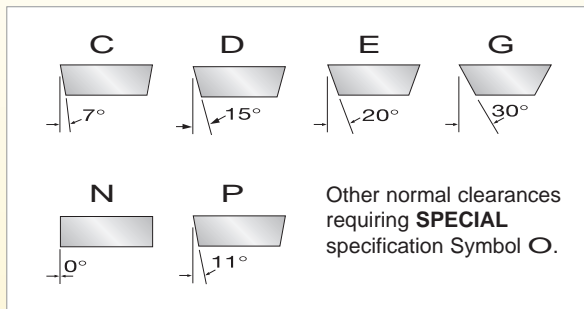

3 Tolerance

	Class	D	M	S	
	A ⁽¹⁾	mm	±0,025	±0,005	
	C ⁽¹⁾	mm	±0,025	±0,013	
	E ⁽¹⁾	mm	±0,025	±0,025	
	F ⁽¹⁾	mm	±0,013	±0,005	
	G	mm	±0,025	±0,025	
	H ⁽¹⁾	mm	±0,013	±0,013	
		J ⁽¹⁾	mm	from ±0,050 to ±0,150	±0,005
		K ⁽¹⁾	mm	from ±0,050 to ±0,150	±0,013
		L ⁽¹⁾	mm	from ±0,050 to ±0,150	±0,025
		M	mm	from ±0,050 to ±0,150	from ±0,080 to ±0,200
N		mm	from ±0,050 to ±0,150	from ±0,080 to ±0,200	
U		mm	from ±0,080 to ±0,250	from ±0,130 to ±0,380	

(1) Indexable inserts with ground wiper edges. (2) Dependent upon the insert size (see ISO 1832 standard)

4 Type

